

SR50GP SPRAYING MACHINE

1.operational principle

Put the cement or other similar material (not including water) according to the design rate --- directly feed the mix into hopper (by hand or by feeder), turn plate driven by reducer and the connecting rod, and with this action, the mortar in the the cylinder though the sucking entrance, at the same time, add water by water dosing pump and mixed with high speed, the mixed material is discharged through the screw pump and discharging exit. Compressed air introduced through air compressor conveys the mix to the nozzle through delivery hose and the mix onto the sprayed surface under high velocity.

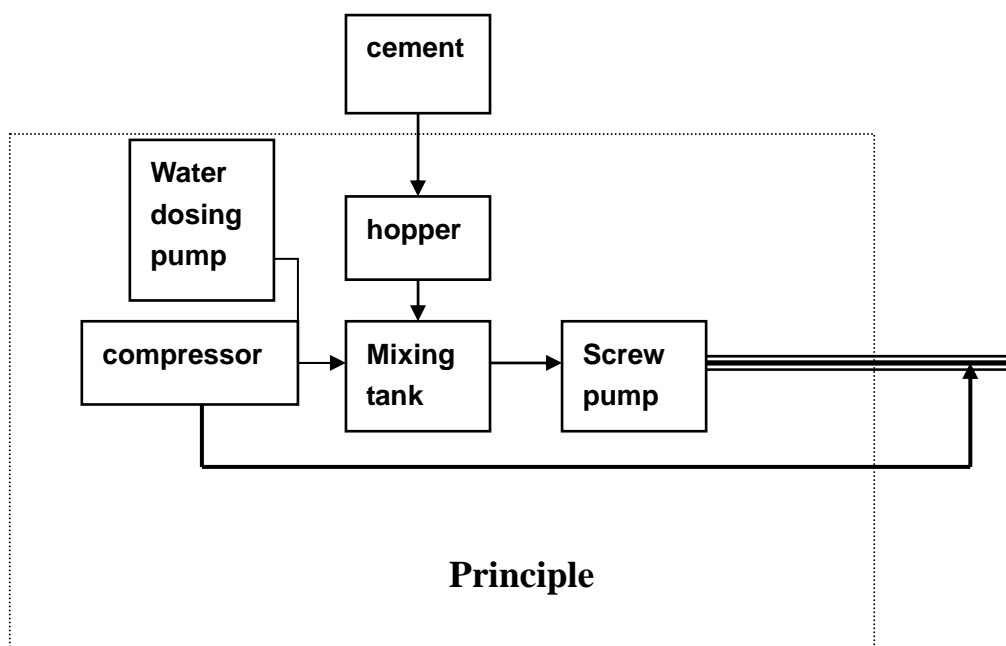

2. structural representation

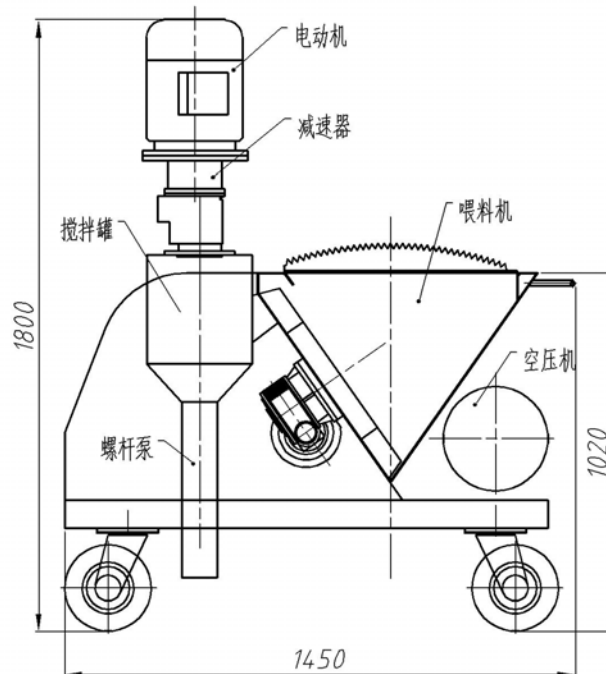

3. Mostly Function

1. Transportation grout;
2. Include hopper and water dosing pump;
3. Include air compressor

4. Detail information

1.output	10~50L/min
2.work pressure	2.5MPa
3.screw speed	400r/min
4.hopper speed	5-30r/min
5.Max. horizontal convey dist.	>50m
6.compressor output	250L/min
7.water pump pressure	10MPa
8.discharge height	1.10m
9.hose inner size	25/32mm
11.air hose inner size	10mm
12.overall dimension(L*W*H)	1450X0.9X1.8m
13.weight	<298kg

